

PRODUCT NUMBER

SEE NOTE 1

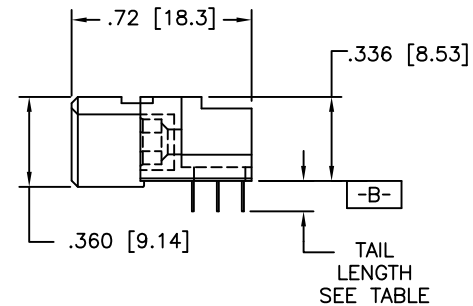

mat'l. code		surface		tolerance		projection		product family	
NOTE 3		ISO 1902		ISO 406		ISO 1101		HPC	
ltr	ec'n no	dr	date	tolerances unless otherwise specified		INCH/MM		title	
L	v00253	JWS	1/12/00	angles	linear	.XX ±.01/.XX±0.3		3 ROW R/A RECEPTACLE	
M	v03-0301	TAB	4/30/03			.XXX ±.005/.XXX±0.13		SOLDER TAIL, 0 GUIDE PIN	
N	v05-0700	DAU	8/25/05	σ±2'		.XXX ±.0020/.XXX±0.051		scale 1:1	
P	M06-0255	AEA	7/06/06	dr	D. SHEAFFER	1/04/90		dwg no	
R	M07-0331	AGS	7/18/07	engr	S. CLARK	1/04/90		sheet 1 of 4 size	
S	M07-0183	MHT	7/22/08	chr	S. CLARK	1/04/90		50000 A3	
T	M08-0280	AGS	30/09/08	appd	S. CLARK	1/04/90		type Product Customer Drawing	
sheet	revision	T	T	T	T				
index	sheet	1	2	3	4				

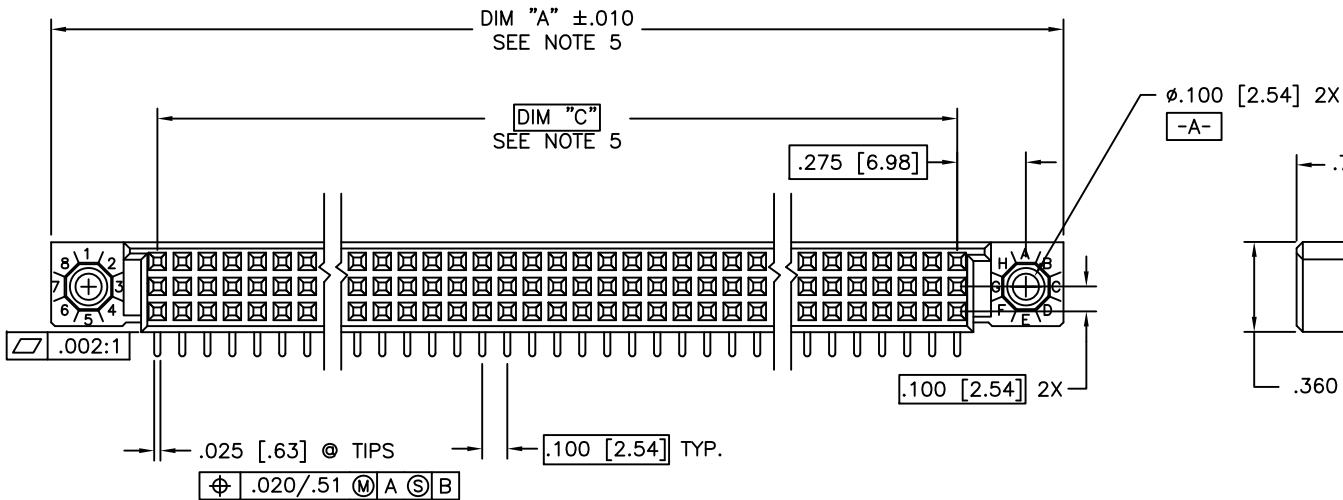
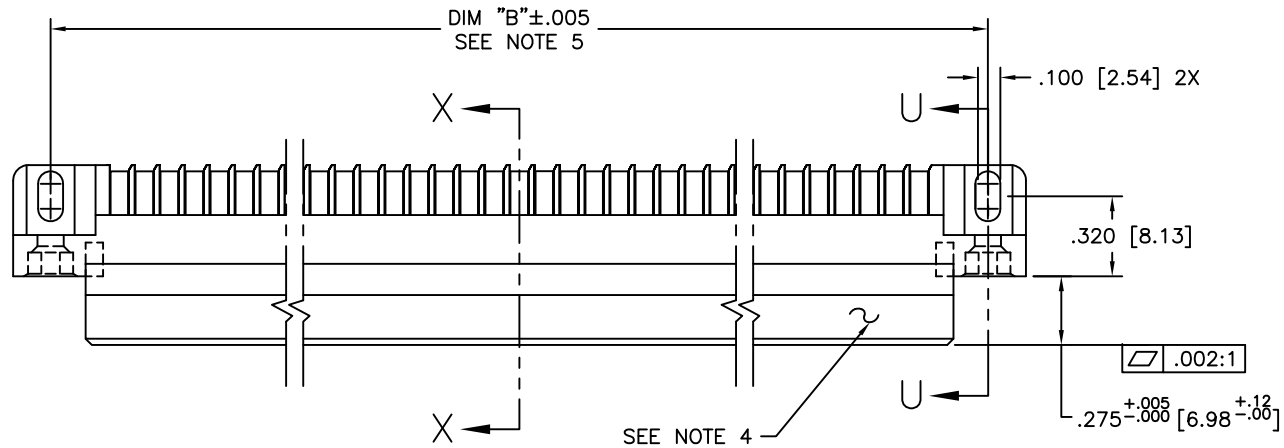

Copyright FCI

form A3

PRODUCT NUMBER  
SEE TABLE

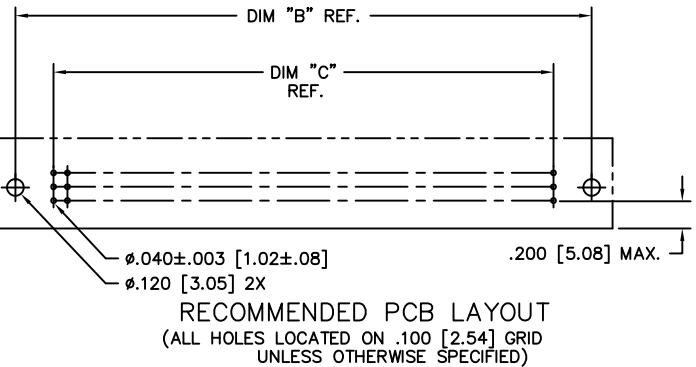
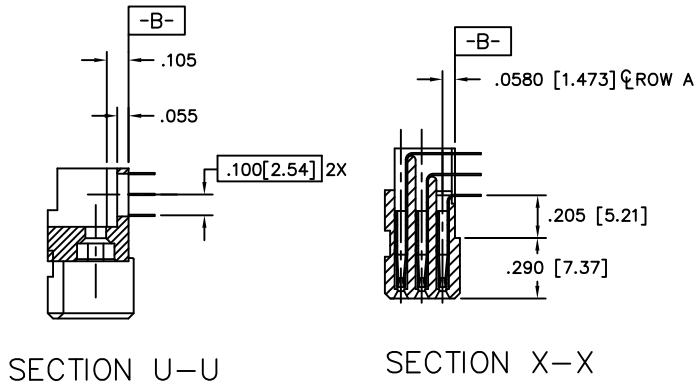

NOTES:  
 ① PRODUCT NUMBERING CODE:  
 50000 - X YYY Z LF  
 LEAD FREE (OPTIONAL)  
 TAIL LENGTH (SEE TABLE)  
 NO. OF POSITIONS (SEE NOTE 2)  
 PLATING (SEE TABLE)  
 BASE NUMBER

PRODUCT NUMBERING CODE FOR  
 SELECT LOAD PART NUMBERS:  
 50000 - XXYYY LF  
 LEAD FREE (OPTIONAL)  
 SEQUENCE NUMBER  
 ALWAYS 'XX'  
 BASE NUMBER

- ② THIS PRODUCT IS CONFIGURED IN SIZES OF 6 THRU 80 COLUMNS IN INCREMENTS OF ONE.  
i.e.: 6,7,8,9.....79,80.
- ③ HOUSING MATERIAL: GLASS AND MINERAL FILLED THERMOPLASTIC.  
FLAME RETARDANT PER UL94V-0. COLOR: BLACK  
CONTACT MATERIAL: BeCu
- ④ COMPANY NAME, PART NUMBER AND LOT CODE TO APPEAR ON THIS SURFACE PER BUS-12-108.
- ⑤ LENGTH FORMULAS:  
 DIM A = .100/2.54 X NO. OF COLUMNS + .75/19.1  
 DIM B = .100/2.54 X NO. OF COLUMNS + .450/11.43  
 DIM C = .100/2.54 X NO. OF COLUMNS - .100/2.54
- ⑥ PRODUCT WITH "LF" SUFFIX MEETS EUROPEAN UNION DIRECTIVES AND OTHER COUNTRY REGULATIONS AS DESCRIBED IN GS-22-008.
- 7. THIS HOUSING WILL WITHSTAND EXPOSURE TO 260° C PEAK TEMPERATURE FOR 10-30 SECONDS IN A CONVECTION, INFRA-RED OR VAPOR PHASE REFLOW OVEN.
- ⑧ PLATING OPTION:  
MAY BE EITHER GOLD OR GXT PLATED AT MANUFACTURER'S OPTION.

mat'l. code		surface		tolerance		projection		product family	
NOTE 3		ISO 1902		ISO 406 ISO 1101				HPC	
ltr	ecn no	dr	date	tolerances unless otherwise specified		INCH/MM		title	
T				angles	linear	$.XX \pm .01 / .XX \pm 0.3$ $.XXX \pm .005 / .XXX \pm 0.13$ $.XXX \pm .0020 / .XXX \pm 0.051$		3 ROW R/A RECEPTACLE SOLDER TAIL, 0 GUIDE PIN	
				$\sigma \pm 2^\circ$		scale 1:1		dwg no	
				dr	D. SHEAFFER	1/04/90		sheet 2 of 4 size	
				engr	S. CLARK	1/04/90		50000 A3	
				chr	S. CLARK	1/04/90		type	
				appd	S. CLARK	1/04/90		Product Customer Drawing	
sheet index	revision sheet								

PRODUCT NUMBER NOTE 1	NUMBER OF POSITIONS NOTE 2	TAIL LENGTH	SOLDER TAIL PLATING	CONTACT PLATING (NOTE 8)
50000-1YYYYE	YYY	.125±.010/3.18±0.25	TIN-LEAD	30u"/0.76um Au
50000-1YYYELF	YYY	.125±.010/3.18±0.25	TIN	30u"/0.76um Au
50000-1YYYYF	YYY	.145±.010/3.68±0.25	TIN-LEAD	30u"/0.76um Au
50000-1YYYYH	YYY	.180±.010/4.57±0.25	TIN-LEAD	30u"/0.76um Au
50000-1YYYYZ	YYY	.220±.010/5.59±0.25	TIN-LEAD	30u"/0.76um Au
50000-3YYYYE	YYY	.125±.010/3.18±0.25	TIN-LEAD	50u"/1.27um Au
50000-3YYYYF	YYY	.145±.010/3.68±0.25	TIN-LEAD	50u"/1.27um Au
50000-3YYYYH	YYY	.180±.010/4.57±0.25	TIN-LEAD	50u"/1.27um Au
50000-3YYYYZ	YYY	.220±.010/5.59±0.25	TIN-LEAD	50u"/1.25um Au
50000-5YYYYE	YYY	.125±.010/3.18±0.25	TIN-LEAD	30u"/0.76um GXT
50000-5YYYELF	YYY	.125±.010/3.18±0.25	TIN	30u"/0.76um GXT
50000-5YYYYF	YYY	.145±.010/3.68±0.25	TIN-LEAD	30u"/0.76um GXT
50000-5YYYYFLF	YYY	.145±.010/3.68±0.25	TIN	30u"/0.76um GXT
50000-5YYYYH	YYY	.180±.010/4.57±0.25	TIN-LEAD	30u"/0.76um GXT
50000-5YYYYHLF	YYY	.180±.010/4.57±0.25	TIN	30u"/0.76um GXT
50000-5YYYYZ	YYY	.220±.010/5.59±0.25	TIN-LEAD	30u"/0.76um GXT
50000-5YYYYZLF	YYY	.220±.010/5.59±0.25	TIN	30u"/0.76um GXT



Copyright FCI

mat'l. code NOTE 3		surface ISO 1802	tolerance ISO 406 ISO 1101	projection 	product family HPC
ltr	ecr no	dr	date	tolerances unless otherwise specified	title 3 ROW R/A RECEPTACLE SOLDER TAIL, 0 GUIDE PIN
T				linear XX ±.01/XX±0.3 XXX ±.005/XXX±0.13 XXXX ±.0020/XXXX±0.051	INCH/MM scale 1:1
		dr	D. SHEAFFER	1/04/90	dwg no 50000
		enr	S. CLARK	1/04/90	sheet 3 of 4 size A3
		chr	S. CLARK	1/04/90	type Product Customer Drawing
		appd	S. CLARK	1/04/90	
sheet index	revision sheet				

PRODUCT NUMBER  
SEE TABLE

# 50000-XX001 OR 50000-XX001LF ONLY

	55					50					45					40					36									
<u>C</u>	C	C	C	C	C	C	C	C	C	C	C	C	C	C	C	C	C	C	C	C	C	C	C	C	C	C	C	C	C	C
<u>B</u>		B		B		B		B		B	B		B		B	B		B		B	B		B		B	B		B		B
<u>A</u>	A	A	A	A	A	A	A	A	A	A	A	A	A	A	A	A	A	A	A	A	A	A	A	A	A	A	A	A	A	A

35					30					25					20					15					10					5					1				
C	C	C	C	C	C	C	C	C	C	C	C	C	C	C	C	C	C	C	C	C	C	C	C	C	C	C	C	C	C	C	C	C	C	C	C	C	C	C	C
																									B	B	B	B	B	B	B	B	B	B	B	B	B	B	B
A	A	A	A	A	A	A	A	A	A	A	A	A	A	A	A	A	A	A	A	A	A	A	A	A	A	A	A	A	A	A	A	A	A	A	A	A	A	A	A

NOTES FOR 50000-XX001 OR 50000-XX001LF ONLY:

- ALL POSITIONS ARE LOADED AS SHOWN.
- COLUMN 1, ROW A IS DESIGNATED AS SIGNAL TERM. 1, AS VIEWED FROM THE MATING FACE.
- SIGNAL DATA FOR 50000-XX001 OR 50000-XX001LF  
 SIZE 3 X 55  
 TOTAL NUMBER OF POSITIONS: 165  
 TOTAL NUMBER OF POSITIONS LOADED: 107

ITEM KEY	QTY.	TAIL LENGTH
A	45	.180±.010/4.57±.25
B	17	.180±.010/4.57±.25
C	45	.180±.010/4.57±.25

mat'l. code		surface		tolerance		projection		product family	
NOTE 3		ISO 1802		ISO 406 ISO 1101				HPC	
ltr	ecr no	dr	date	tolerances unless otherwise specified		INCH/MM		title	
T				angles	linear	$.XX \pm .01 / .XX \pm 0.3$ $.XXX \pm .005 / .XXX \pm 0.13$ $.XXXX \pm .0020 / .XXXX \pm 0.051$		3 ROW R/A RECEPTACLE SOLDER TAIL, 0 GUIDE PIN	
				$\sigma \pm 2'$		scale 1:1		dwg no	
				dr	D. SHEAFFER	1/04/90		sheet 4 of 4 size	
				enr	S. CLARK	1/04/90		50000 A3	
				chr	S. CLARK	1/04/90		type	
				appd	S. CLARK	1/04/90		Product Customer Drawing	
sheet index	revision sheet								